

# A3 PRO V2

## User Manual

V1.1 Oct, 2021 Revision

Thank you for purchasing our products. A3 Pro V2 is a high-performance and functional 6-axis gyro and stabilizer designed for R/C airplanes. In order for you to make the best use of your gyro and to fly safely, please read this instruction manual carefully and set up the device as described below.

### IMPORTANT NOTES

- Radio controlled (R/C) models are not toys! The propellers rotate at high speed and pose potential risk. They may cause severe injury due to improper usage. It is necessary to observe common safety rules for R/C models and the local law. Read the following instructions thoroughly before the first use of your gyros and setup the gyro carefully according to this manual. We also recommend that you seek the assistance of an experienced pilot before attempting to fly with our gyros for the first time.
- After power on, A3 Pro V2 needs to perform an accurate gyroscope calibration, keep the airplane stationary after power on and wait while the LED flashes blue. The LED will stay solid blue if a slight movement is detected and the calibration will not start until you stop moving the airplane, however, making the airplane level is NOT required during the initialization.
- A stick centering is also required following the gyroscope calibration. Always put all the sticks center (the throttle stick in the lowest position) before power on the airplane, and do not move the sticks until the initialization is done.
- Make sure to check the gyro direction of Aileron, Elevator and Rudder channels after installation and always perform a test of them before each flight. An opposite reaction of the gyro could lead to losing control or even crash!
- It is recommended to use the supplied 3300uF/16V capacitor to get a more stable and secure working voltage for the gyro. The capacitor can be plugged onto any one of the free connectors of the gyro or receiver.

# INSTALLATION

## ⚠ NOTES

- Never use the hot-melt glue or nylon ties to fix the gyro onto the airplane!
- You need only one piece of the tapes each time, a soft or thick mounting may probably impact the performance of the gyro.
- The gyro is a sensing device, please make enough space around it and keep as far away from other electronic devices or wires as possible.

## MOUNTING ORIENTATION

Use one of the supplied double-sided tape to attach the gyro to your airplane firmly. For best performance, the gyro should be mounted as close to the C.G. as possible, and the housing edges must be aligned exactly parallel to all three rotation axes of the plane. The gyro can be attached flat or upright, and even upside down, however, you have to ensure the arrow on the sticker always point to the heading direction, otherwise the gyro will not work normally in ANGLE, LEVEL and HOVER modes.

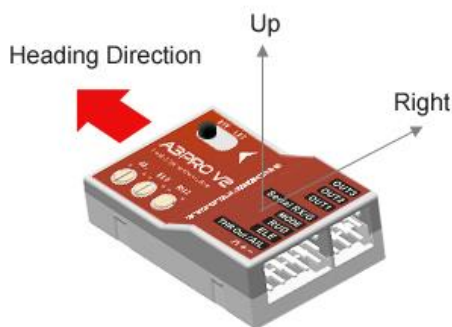

① Flat, face up

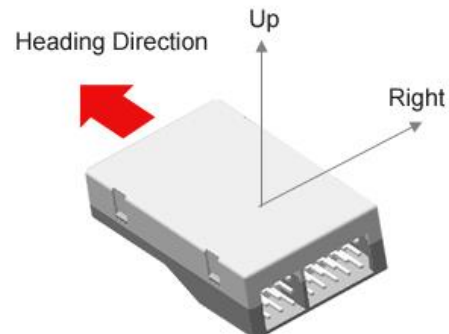

② Flat, face down

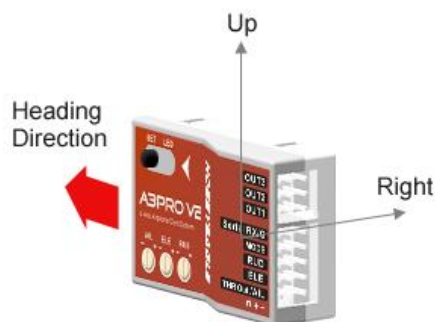

③ Upright, button up

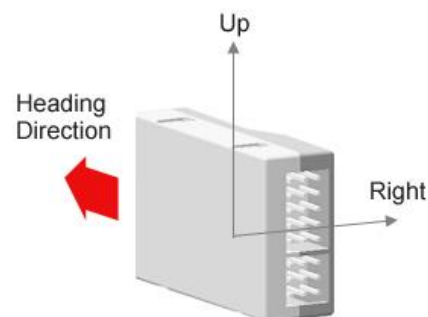

④ Upright Inverted, button down

# CONNECTION

## STANDARD PWM RECEIVER CONNECTION

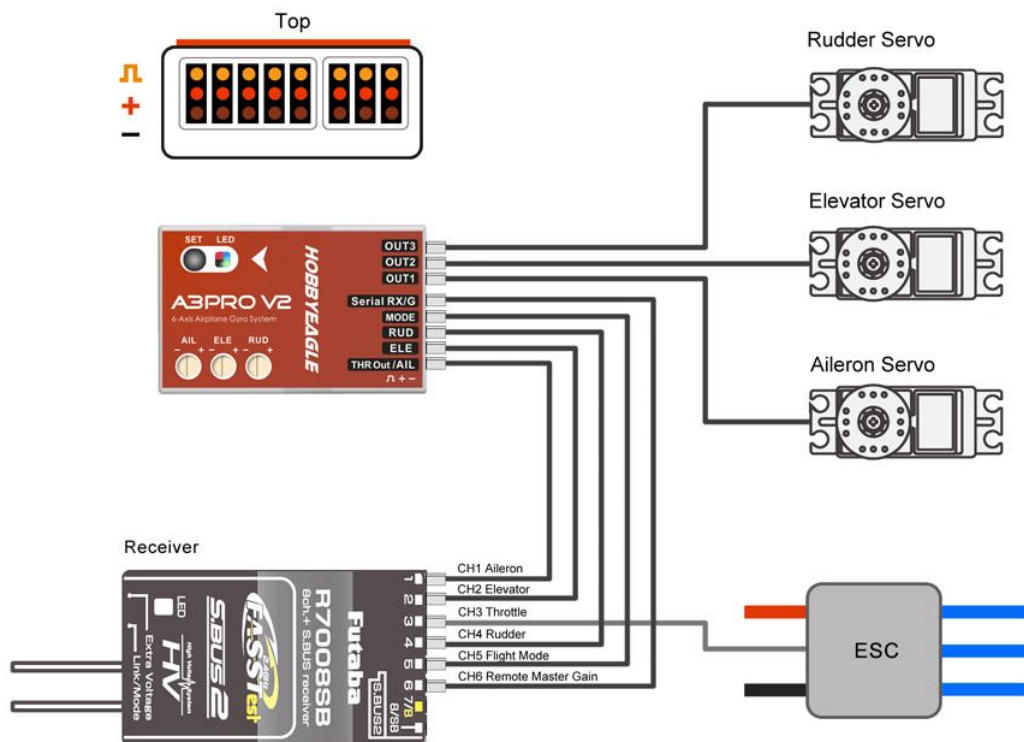

### ! NOTES

- [MODE] is used for flight mode switching of the gyro, connect it to a 3-way switch channel of the receiver to switch the flight mode in flight.
- [Serial RX/G] is used for remote master gain adjusting, connect it to a proportional channel of a volume or slide lever of the transmitter to tune the master gain in flight.
- The ESC or throttle servo is connected to the throttle channel of the receiver directly without passing through the gyro.
- Pay attention to the polarity of the plugs. The orange signal line must always be on the top and the brown on the bottom.

## SINGLE-LINE RECEIVER CONNECTION

A3 Pro V2 supports PPM and multi-protocol digital serial receivers which allows you to connect the gyro to the receiver with one single wire. When using a specific type of these receivers the appropriate type of receiver channel allocation will be preset in the A3 Pro V2. Please refer to the table below and check if your radio transmits the channels in the correct order. If this is not the case, you have to change the channel mapping in the *Receiver Menu*. If you use a standard PWM receiver with standard wiring layout

the channel mapping does not apply. When A3 Pro V2 is operating in single line receiver mode, the [THR Out/AIL] can be used as the throttle output channel for the ESC or the throttle servo if a mini receiver is being used which has no additional output connectors.

**Table 1: Serial Receiver Protocols Supported and Default Channel Assignment**

Serial Receiver Protocol	AIL	ELE	THR	RUD	MODE	GAIN
PPM Receiver	CH1	CH2	CH3	CH4	CH5	None
Futaba S.Bus (FrSky SBUS or WFLY WBUS)	CH1	CH2	CH3	CH4	CH5	None
Spektrum DSM/DSMX 1024 Satellite	CH2	CH3	CH1	CH4	CH5	None
Spektrum DSM/DSMX 2048 Satellite	CH2	CH3	CH1	CH4	CH5	None
Spektrum SRXL	CH2	CH3	CH1	CH4	CH5	None
Multiplex SRXL/JR XBUS Mode B	CH2	CH3	CH1	CH4	CH5	None
Graupner SUMD	CH2	CH3	CH1	CH4	CH5	None
FlySky iBUS	CH1	CH2	CH3	CH4	CH5	None

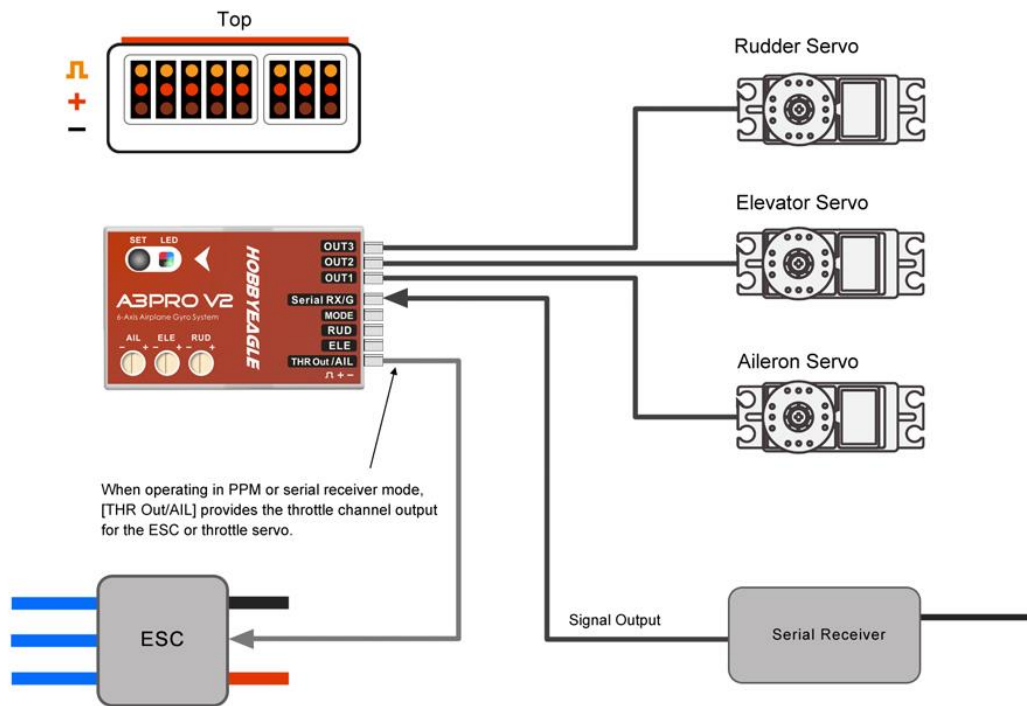

### ⚠ NOTES

- Please note that the remote master gain channel is disabled in single line mode as default. Assign a channel number for gain channel in *Receiver Menu* to activate this feature if needed.
- Pay attention to the polarity of the plugs. The orange signal line must always be on the top and the brown on the bottom.
- You will need to purchase an optional adapter if you are using a Spektrum satellite receiver.

# FLIGHT MODES

A3 Pro V2 provides 6 flight modes which can be switched by a 3-position switch of the transmitter during flight. The factory default mode allocation of the switch is **OFF - NORMAL - LEVEL**. You can change the settings in the *Setup Menu* according to your needs. The color of the LED shows the current flight mode of the gyro while in use.

## COLORS OF THE LED FOR FLIGHT MODES

	Solid Red	GYRO OFF Mode
	Solid Blue	NORMAL Mode
	Blue, Flashing	LOCK Mode
	Solid Violet	ANGLE Mode
	Violet, Flashing	LEVEL Mode
	Violet, Fast Flashing	HOVER Mode

## 1. GYRO OFF MODE

When operating in *GYRO OFF* mode the gyro will be deactivated completely, and the airplane will be completely under the control of your transmitter as it was before installing the gyro. This mode is usually used for testing purpose only.

## 2. NORMAL MODE

The *NORMAL* mode, also known as the '*Rate mode*', is the most basic function of the gyro. It works based on the rotation rate control of each axis of the airplane. When operating in this mode, the gyro will only correct currently occurring rotational movements, a momentary reaction will be applied to the servos when the airplane rotating on corresponding axis, after rotation the servos will move back to their neutral position as soon as the airplane standing still immediately. The *NORMAL* mode can be used with nearly any size and type of airplanes. It can effectively improve the stability and precision of the airplane and reduce the stall point specially.

## 3. LOCK MODE

The *LOCK* mode is also known as the '*Attitude Lock mode*', '*3D mode*' or '*AVCS mode*'. Different from *NORMAL* mode, the gyro will perform a permanent correction for rotational movements on each axis constantly. That is when you release the sticks the airplane will stop and lock its current position immediately. This mode is well suited for practicing basic 3D maneuvers such as hovering or knife edge. Since it can help you to lock the attitude of the airplane, it is also helpful for landing.

## 4. ANGLE MODE (FORMER TRAINER MODE)

The *ANGLE* mode, also known as the '*Trainer mode*' or '*Attitude mode*', will limit the maximum angle of

the airplane on both roll and pitch axes. Roll and loop are not allowed in this mode, the airplane will be stabilized all the time, independent of any stick input. This prevents the airplane from being tilted into a larger angle that may cause a danger. As soon as the sticks are released, the airplane will be brought back to horizontal position automatically. You can use this mode as emergency rescue, or in other applications, e.g., to have a training for new beginners or to use for FPV. The maximum allowed angle can be set in the *Setup Menu*. In addition, changing the stick rate can also affect the max tilt angle.

## 5. LEVEL MODE

The *LEVEL* mode is also known as the '*Auto-Level mode*', '*Auto-Balance mode*' or '*Horizon mode*'. When operating in this mode, the airplane will be brought to horizontal position automatically when releasing the sticks. Different from the *ANGLE* mode, there is no maximum angle limitation in this mode and the airplane will be stabilized only when there is no specific control input from aileron and elevator sticks. This mode can be used if the pilot becomes disoriented and would like to save the airplane from crashing.

## 6. HOVER MODE

The *HOVER* mode, also known as the '*Auto-Hover mode*', provides the same functionality as the *LEVEL* mode. The only difference is that when you release the sticks, the airplane will be brought to vertical position (nose up) and keeps hovering. This mode is designed to help you to learn hovering maneuver and reduce the probability of crashing.

# GAIN ADJUSTMENT

## BASIC GAIN

There are 3 trimming potentiometers on the front of the A3 Pro V2. They are used to adjust the basic gain of the gyro for Aileron, Elevator and Rudder separately. Clockwise for increase, anticlockwise for decrease. Basic gain determines the momentary reaction strength of the gyro. In general, the higher the gain the harder the airplane will stop after rotation and the more stable and precise the airplane will fly. But if the gain is too high the airplane will tend to oscillate at high frequency on the corresponding axis. If too small, the operation and stability will not be so good and the airplane does not stop precisely and overshoots. The gyro will be deactivated completely if you turn the basic gain to 0%.

For the first flight test it is recommended to start with a lower basic gain setting (e.g. 30%) and switch the gyro to *NORMAL* mode. In case the airplane starts to oscillate in flight then reduce the gain of the corresponding axis. If the control feels weak and imprecise and does not hold position when stopping then increase the gain, according to this approach, fine tune the basic gain until you get the best performance.

## REMOTE MASTER GAIN

The [Serial RX/G] is used to control the master gain remotely. You can make a linear adjustment by using a volume or slide lever on your transmitter or make a 3-level gain selection using a 3-position switch. This

function is optional, the master gain will always default to 100% if you do not connect it.

## SETTING METHOD

There are 2 menus provided for setting up the gyro which can be accessed by the following ways:

### **Setup Menu:**

When the gyro is working, press and hold the button for 2 seconds, release the button when LED starts flashing White quickly.

### **Receiver Menu:**

Turn the gyro on while holding down the button, release the button when LED lights Violet.

## SETUP MENU

### MENU ACCESSING

To get into the *Setup Menu*, press and hold the button for about 2 seconds until the LED starts flashing White quickly. The *Setup Menu* contains 10 setting functions which normally only need to be setup once after installation.

Press and hold the button for about 2 seconds



Operation Mode

Release the button when LED starts flashing White



Setup Menu

### FUNCTION SELECTION

In the *Setup Menu*, the LED will flash White several times every 3 seconds in a loop and the number of times LED flashes shows at which function item you are currently. For example, one White flashing means the first setting “Wing Type”, after waiting about 3 seconds, a twice White flashing means the second setting “Mount Orientation”, and so on.

### OPTION SWITCHING

When you reach the function that you wish to operate in, short press the button to get into it. After entering in, the current selected option is indicated by the color of the LED. Each short press of the button advances the option to the next value. After you finish making your selection, just wait for 5 seconds until the LED starts blink quickly which indicates that the modified is saved and then you will be brought back to the *Setup Menu* level automatically. If you do not want to change anything, just wait for timeout without any operation.

### EXIT OF MENU

To exit the menu keep the button pressed for 2 seconds again until the LED starts flashing White quickly.

## SETUP MENU TABLE (\* is the default setting)

	Functions	LED Status	Solid Red	Solid Green	Solid Blue	Solid Yellow	Solid White	Solid Violet
1	Wing Type	White, 1 flash	Standard *	Delta-wing	V-Tail			
2	Mount Orientation	White, 2 flashes	Flat *	Flat Inverted	Upright	Upright Inverted		
	Flight Mode	White, 3 flashes						
3	1 Position-1	Blue, 1 flash	OFF *	NORMAL	LOCK	ANGLE	LEVEL	HOVER
	2 Position-2	Blue, 2 flashes	OFF	NORMAL *	LOCK	ANGLE	LEVEL	HOVER
	3 Position-3	Blue, 3 flashes	OFF	NORMAL	LOCK	ANGLE	LEVEL *	HOVER
4	Gyro Direction	White, 4 flashes						
	1 Aileron	Blue, 1 flash	Normal *	Reversed				
	2 Elevator	Blue, 2 flashes	Normal *	Reversed				
	3 Rudder	Blue, 3 flashes	Normal *	Reversed				
5	Level Calibration	White, 5 flashes						
6	Hover Calibration	White, 6 flashes						
7	Maximum Angle	White, 7 flashes	± 30°	± 60° *	± 90°			
8	Servo Frequency	White, 8 flashes	50Hz *	65Hz	165Hz	200Hz	270Hz	333Hz
9	Gain Level	White, 9 flashes	Small	Medium *	Large			
10	Factory Reset	White, 10 flashes						

### 1. WING TYPE

A3 Pro V2 supports standard fixed-wing, flying-wing (delta-wing) and V-tail. After entering in this function, the color of LED shows you the wing type currently selected. The default setting is Standard (Red), each short press of the button will switch to the next type. After you finish making your selection, just wait for 5 seconds until LED starts blink quickly which indicates that the modified is saved and then you will be brought back to the *Setup Menu* level automatically. If you do not want to change anything, just wait for timeout without any operation.

LED Color	Description
Solid Red	Standard (default)
Solid Green	Flying-wing (Delta-wing)
Solid Blue	V-Tail

#### NOTES

- Make sure that there are no mixing functions active on your transmitter. Have a look at the radio's servo monitor and verify that each stick controls only one output channel.
- If two aileron servos are being used, please connect a Y-extended lead to [OUT1].
- Most flying-wings have no rudder, in this case, [RUD] is unnecessary to connect.



Standard Wing Type

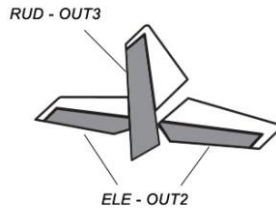
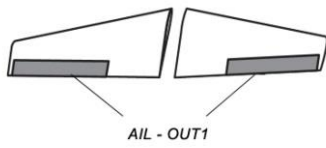

Flying Wing (Delta)

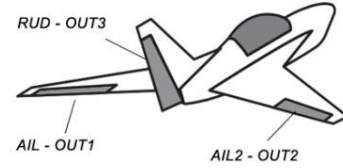

V-TAIL

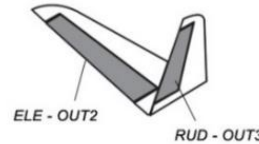
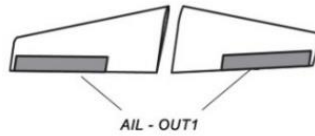

## 2. MOUNT ORIENTATION

A3 Pro V2 can be mounted flat or upright, and even upside down, however, you have to ensure the arrow on the sticker always point to the heading direction. After entering in this function, the color of LED shows you the orientation currently selected. The default setting is Flat, face up (Red), each short press of the button will switch to the next type. After you finish making your selection, just wait for 5 seconds until LED starts blink quickly which indicates that the modified is saved and then you will be brought back to the *Setup Menu* level automatically.

LED Color	Description
Solid Red	Flat, Face up (default)
Solid Green	Flat, Face down
Solid Blue	Upright
Solid Yellow	Upright Inverted

If you do not want to change anything, just wait for timeout without any operation.

The setting here should be the same as the mounting orientation of your unit installed in the airplane, otherwise the gyro will not work normally.

## 3. FLIGHT MODE

This function allows you preset the desired flight mode for each position of the switch. Short press the button when LED is flashing 3 times in the *Setup Menu* to get into the *Position Selection Menu*. In this second-level menu, LED will flash Blue several times every 3 seconds in a loop and the number of times LED flashes shows at which position you are currently. For example, one Blue flashing means "position-1", after waiting about 3 seconds, a twice Blue flashing means "position-2", and so on.

LED Color	Description
Solid Red	GYRO OFF Mode
Solid Green	NORMAL Mode
Solid Blue	LOCK Mode
Solid Yellow	ANGLE Mode
Solid White	LEVEL Mode
Solid Violet	HOVER Mode

When you reach the position that you wish to set, short press the button to get into it. After entering in the color of LED shows you the flight mode currently selected for this position. Each short press of the button will switch to the next mode. After you finish making your selection, just wait for 5 seconds until LED starts blink quickly which indicates that the modified is saved and then you will be brought back to the *Position Selection Menu* level automatically.

To get out of the *Position Selection Menu* just keep the button pressed (2 seconds) again until LED starts flashing Blue quickly, then you will be brought back to the *Setup Menu*.

## 4. GYRO DIRECTION

Here you can reverse the gyro direction for *Aileron*, *Elevator* and *Rudder*. Short press the button when LED is flashing 4 times in the *Setup Menu* to get into the *Channel Selection Menu*. In this second-level menu, LED will flash Blue several times every 3 seconds in a loop and the number of times LED flashes shows at which channel you are currently. For example, one Blue flashing means “Aileron”, after waiting about 3 seconds, a twice Blue flashing means “Elevator”, and so on.

LED Color	Description
Solid Red	Normal (default)
Solid Green	Reversed

When you reach the channel that you wish to set, short press the button to get into it. After entering in the color of LED shows you the direction currently selected for this channel. Each short press of the button will switch between *Normal* and *Reversed*. After you finish making your selection, just wait for 5 seconds until LED starts blink quickly which indicates that the modified is saved and then you will be brought back to the *Channel Selection Menu* level automatically.

To get out of the *Channel Selection Menu* just keep the button pressed (2 seconds) again until LED starts flashing Blue quickly, then you will be brought back to the *Setup Menu*.

### **VERY IMPORTANT!**

It is extremely important to make sure that the gyro reacts in the correct direction for each channel before flight. An opposite reaction of the gyro could lead to losing control or even crash!

### Check the gyro direction for Aileron

Quickly move the right wing downward around the roll axis, the right aileron surface should flap down and the left flap up as shown below.

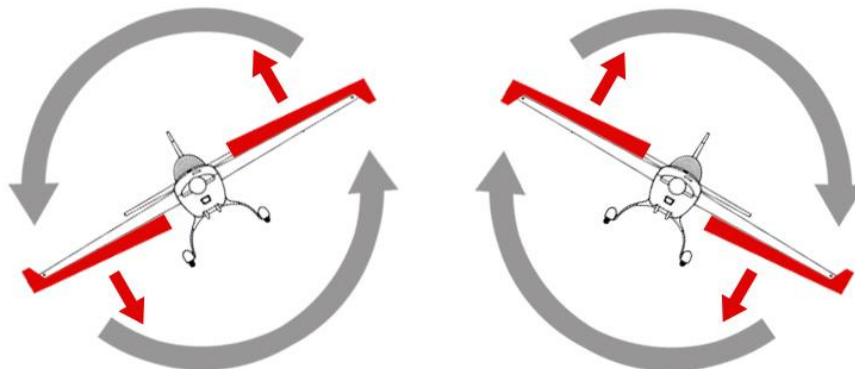

### Check the gyro direction for Elevator

Quickly move the nose of the airplane downward around the pitch axis, the elevator surface should flap

up as shown below.

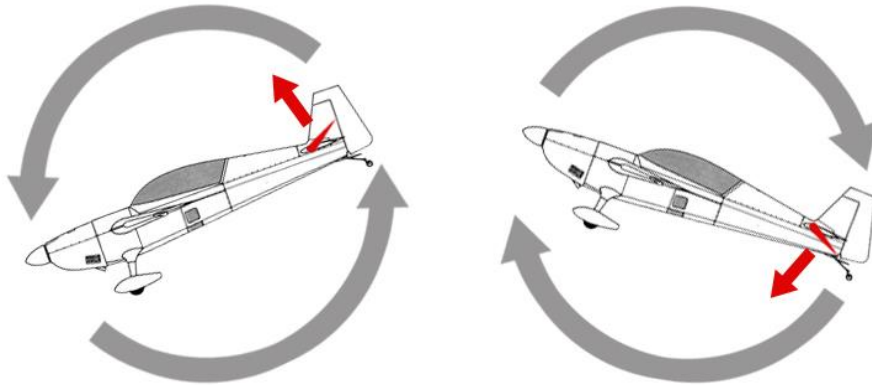

### Check the gyro direction for Rudder

Quickly move the nose of the airplane to the left around the yaw axis, the rudder surface should flap right as shown below.

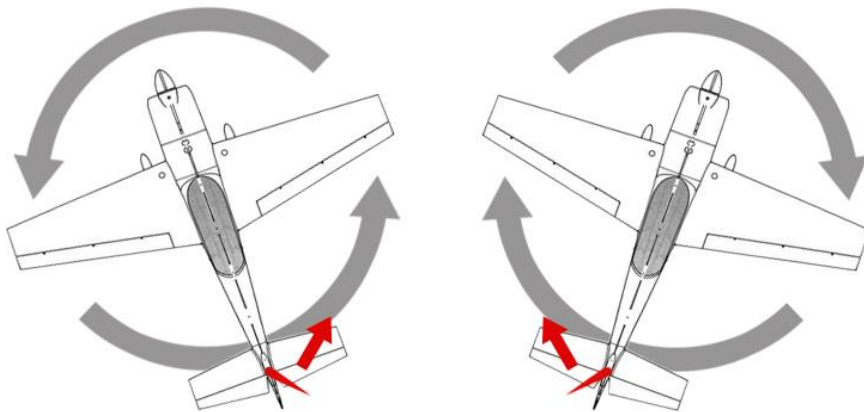

## 5. LEVEL CALIBRATION

When flying in *ANGLE* mode or *LEVEL* mode, A3 Pro V2 needs to know the angle of the airplane in both roll and pitch directions, this is achieved by calculating the attitude of its own. A small angle deviation caused by installation can lead to an unexpected behavior when flying in *ANGLE* mode or *LEVEL* mode. For this reason, a level calibration is recommended to offset the error caused by installation and to establish a proper level reference of your airplane after installing the gyro.

Before calibrating, the airplane should be placed on the horizontal ground and make the wing parallel to the ground. Make the airplane slightly nose-up because a certain elevation angle is usually required to maintain level flight for most airplanes.

Short press the button when LED is flashing 5 times in the *Setup Menu*, then LED will start blink Blue rapidly for several seconds, do not move the airplane and keep its attitude until the calibration is done.

## 6. HOVER CALIBRATION

As a same reason, a hover calibration is recommended to perform after installation if you want to fly with

*HOVER* mode. The procedure is quite similar to that of level calibration. The only difference is in the first step. Before calibrating, you need to lift the airplane and make it vertical to the ground instead of putting it on the ground.

Short press the button when LED is flashing 6 times in the *Setup Menu*, then LED will start blink Blue rapidly for several seconds, do not move the airplane and keep its attitude until the calibration is done.

## 7. MAXIMUM ANGLE

This function is used to setup the maximum allowed tilt angle of the airplane for *ANGLE* mode.

After entering in this function, the color of LED shows you the angle currently selected. The default setting is  $\pm 60$ deg (Green), each short press of the button will switch to the next value. After you finish making your selection, just wait for 5 seconds until LED starts blink quickly which indicates that the modified is saved and then you will be brought back to the *Setup Menu* level automatically.

LED Color	Description
Solid Red	$\pm 30^\circ$
Solid Green	$\pm 60^\circ$ (default)
Solid Blue	$\pm 90^\circ$

If you do not want to change anything, just wait for timeout without any operation.

## 8. SERVO FREQUENCY

This function is used to set the working frequency of the servos. The analog servos can only work with 50Hz. If you do not know what the maximum update rate that is tolerated by your servos never use more that 50Hz. The higher the frequency the better it is for the flight performance of the gyro but you must check the servo specifications before increasing the setting. Otherwise, the servos may get damaged!

After entering in this function, the color of LED shows you the frequency currently selected. The default setting is 50Hz (Red), each short press of the button will switch to the next value. After you finish making your selection, just wait for 5 seconds until LED starts blink quickly which indicates that the modified is saved and then you will be brought back to the *Setup Menu* level automatically.

LED Color	Description
Solid Red	50Hz (default)
Solid Green	65Hz
Solid Blue	165Hz
Solid Yellow	200Hz
Solid White	270Hz
Solid Violet	333Hz

If you do not want to change anything, just wait for timeout without any operation.

## 9. GAIN LEVEL

This function is used to change the level of the basic gain. After entering in this function, the color of LED shows you the gain level currently selected. The default setting is Medium (Green), each short press of the button will switch between *Small*, *Medium* and *Large*. After you finish making your selection, just wait for 5 seconds until LED starts blink quickly which indicates that the modified is saved and then you will be brought back to

LED Color	Description
Solid Red	Small
Solid Green	Medium (default)
Solid Blue	Large

the *Setup Menu* level automatically.

If you do not want to change anything, just wait for timeout without any operation.

## 10. FACTORY RESET

This function is used to reset the gyro to factory settings. After entering in this function, the LED will remain flashing Blue, press and hold the button for about 2 seconds until the LED starts flash Blue quickly, release the button to confirm the reset. You will be brought back to the *Setup Menu* level automatically after the restore is done.

## RECEIVER MENU

### MENU ACCESSING

To get into the *Receiver Menu*, press and hold the button while turn on the power supply of the gyro, release it when LED lights solid Violet. In *Receiver Menu* you can change the receiver type and program the channel mapping for single line receivers.



### FUNCTION SELECTION

In the *Receiver Menu*, LED will flash Violet several times every 3 seconds in a loop and the number of times LED flashes shows at which function item you are currently. For example, one Violet flashing means the first setting “Receiver Type”, after waiting about 3 seconds, a twice Violet flashing means the second setting “Aileron channel”, and so on.

### OPTION SWITCHING

When you reach the function that you wish to operate in, short press the button to get into it. After entering in, the current selected option is indicated by the color of the LED. Each short press of the button advances the option to the next value. After you finish making your selection, just wait for 5 seconds until LED starts blink quickly which indicates that the modified is saved and then you will be brought back to the *Receiver Menu* level automatically. If you do not want to change anything, just wait for timeout without any operation.

### EXIT OF MENU

To exit the menu just keep the button pressed for 2 seconds again until the LED starts flashing Violet quickly. After exiting the *Receiver Menu*, the gyro will start the initialization normally, so the new receiver settings will take effect immediately without restarting the gyro.

## RECEIVER MENU TABLE (\* is the default setting)

Functions LED Status	Solid Red	Solid Green	Solid Blue	Solid Yellow	Solid White	Solid Violet	Red Flashing	Green Flashing	Blue Flashing
1 <b>Receiver Type</b> Violet, 1 flash	PWM*	PPM	SBUS	DSM2/X 1024	DSM2/X 2048	Spektrum SRXL	MPX SRXL	SUMD	IBUS
2 <b>Aileron Channel</b> Violet, 2 flashes	None	CH1	CH2	CH3	CH4	CH5	CH6	CH7	CH8
3 <b>Elevator Channel</b> Violet, 3 flashes	None	CH1	CH2	CH3	CH4	CH5	CH6	CH7	CH8
4 <b>Rudder Channel</b> Violet, 4 flashes	None	CH1	CH2	CH3	CH4	CH5	CH6	CH7	CH8
5 <b>Mode Channel</b> Violet, 5 flashes	None	CH1	CH2	CH3	CH4	CH5	CH6	CH7	CH8
6 <b>Gain Channel</b> Violet, 6 flashes	None*	CH1	CH2	CH3	CH4	CH5	CH6	CH7	CH8
7 <b>Throttle Channel</b> Violet, 7 flashes	None	CH1	CH2	CH3	CH4	CH5	CH6	CH7	CH8
8 <b>DSM Bind Option</b> Violet, 8 flashes	None*	DSM2	DSMX						

**Notes:** When you change the serial receiver type, the settings from item 2 to 7 will be overwritten and reset to the default settings (see P4 Table 1). Please check if it is the same as the channel definition of your transmitter.

## ACCELEROMETER CALIBRATION

Before leaving the factory every unit has been carefully tested and calibrated. Usually you do not need to perform a calibration of the accelerometer during use. However, in some specific cases, we would suggest you re-calibrate the accelerometer to obtain better performance, these include temperature changes those will probably cause the mechanical characteristics changes of the sensor, or replacement of new sensor, etc. The calibration should be done on a horizontal desktop and the gyro needs to be removed from the airplane.

### ENTERING THE CALIBRATION PROGRAM

To access the accelerometer calibration program, press and hold the button while turn on the power of the gyro, release it when LED starts flash Violet slowly. (FYA: Do not release the button when LED turns solid Violet yet, or you will get into the *Receiver Menu* but not the accelerometer calibration program.)

Press and hold the button while turn on the power supply



**Power Off Mode**

Don't release when LED turns solid Violet, keep holding the button for 2 seconds



**Receiver Menu**

Release the button until LED starts flashing Violet slowly



**Accel Calibration**

## CALIBRATION STEPS

A3 Pro V2 uses a quick approach for accelerometer calibration, there are only 2 steps corresponding to both sides of Z axis of the unit required to be calibrated. Each step will take about 2 seconds. While calibrating, the LED will flash Blue several seconds and then light up solid in Blue. Do not move the gyro until the calibration is done.

**Step 1** Put the gyro flat and face up on the table and make it parallel to the desktop. short press the button, do not move the gyro while the LED is flashing Blue quickly.

**Step 2** Put the gyro flat and face down on the table and make it parallel to the desktop, short press the button, do not move the gyro while the LED is flashing Blue quickly.

**Finish** After you have finished the 2 steps above, the LED will flash Violet once which indicates that the calibration is complete, after a successful calibration the gyro will start the initialization automatically.

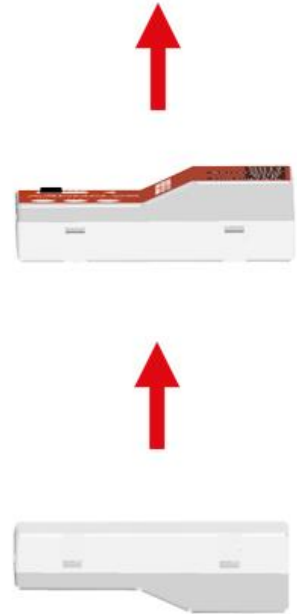

## SPECIFICATIONS

<b>Main Controller:</b>	32-bit MCU
<b>Sensors:</b>	High-precision 3-axis gyroscope and 3-axis accelerometer
<b>Gyroscope Scale Range:</b>	$\pm 2000$ dps
<b>Accelerometer Scale Range:</b>	$\pm 4$ g
<b>PWM:</b>	920uS to 2120uS with 1520uS center length, 50Hz to 333Hz
<b>Input Voltage:</b>	4.8V to 8.4V
<b>Operating Temperature:</b>	-10°C to 50°C
<b>Size:</b>	43 × 27 × 14mm
<b>Weight:</b>	10g (excluding wires)